

Comprehensive Sign Package



March 5, 2007

Revised

April 4, 2007

Revised

June 15, 2007

Revised

July 26, 2007

Revised

August 20, 2007

Revised

September 4, 2007

Revised

September 21, 2007

Revised

November 13, 2007

Revised

April 14, 2008

Revised

December 12, 2008

Revised

June 3, 2009



Prepared for
Pender LLC
By: Atlantic Realty, Inc.
8150 Leesburg Pike, Suite 1100
Vienna, VA 22182
(703) 760-9500

Prepared by
Rounds VanDuzer Architects
467-A North Washington Street
Falls Church, VA 22046
(703) 533-3577

Table of Contents

Introduction..... 3

- Map..... 4
- Logo..... 6
- General Provisions..... 7
- Sign Matrix 8

Sign Types

1. Monument Signs..... 11
 - Pender Village Center (Primary)..... 13
 - Pender Village Center (Secondary)..... 14
 - Pender Mission Center 15
 - Directional Signs (Primary)..... 16
 - Directional Signs (Secondary) 17
2. Tenant Signs..... 18
 - Anchor Tenant 21
 - B-1 Building Retail Signs..... 24
 - 1st Floor Retail..... 25
 - 2nd Floor Office 26
 - Office Entrance and Building Address Identification 27
 - Existing Office Building..... 28
 - Office Building 29
 - Pad Building 30
 - Retail Blade Signs 35
3. Miscellaneous Signs 37
 - Garage Entrance Signs 39
 - Protected Natural Area Sign 41
 - Light Pole Mounted Banners 42
 - Historical Marker 43
 - Flags 44
 - Informational Signs 45
 - Stop/ Yield
 - Handicapped
 - No Parking
 - Play Area
 - Loading / Receiving

Introduction

Pender Village Center (PVC) and Pender Mission Center (PMC)

The purpose of the Comprehensive Sign Package is to establish a cohesive, comprehensive, distinctive, and functional system to direct and communicate with those who work or visit the shops and offices. The signs provide a consistent source of information while reflecting the high standards of design and visual quality, which are a cornerstone of the development.

Well-designed signage is an integral part of any successful project. The purpose of a sign system is to orient, inform, direct, and regulate pedestrian and vehicular traffic. A properly conceived signage system will also enhance the visual quality of the development and enhance the safety of the traveling public.

Signage, as visual communication, is most effective when organized in a comprehensive, cohesive system. The sign system is designed to achieve a consistent display of information throughout the development. The elements of this system reflect and emphasize the architectural style and landscape features of PVC and PMC, and allow for the flexibility this community will need over the next 10 to 15 years as it continues to grow.

The following pages provide illustrations, details, locations, and types of messages, for the various signs on the site. These guidelines assure consistent display of information, and create a comprehensive sign program, which will establish an overall identity, convey information, direct traffic and facilitate access to PVC services and amenities.

Since all new Retail and Retail/Office buildings are proffered and designed with four-sided architecture, maximum signage area is presumed to be (based on Fairfax County standards) as if all sides were street-facing and allowed signage. That the total amount of signage so computed can be allotted where it best directs, advertises and informs is also assumed.



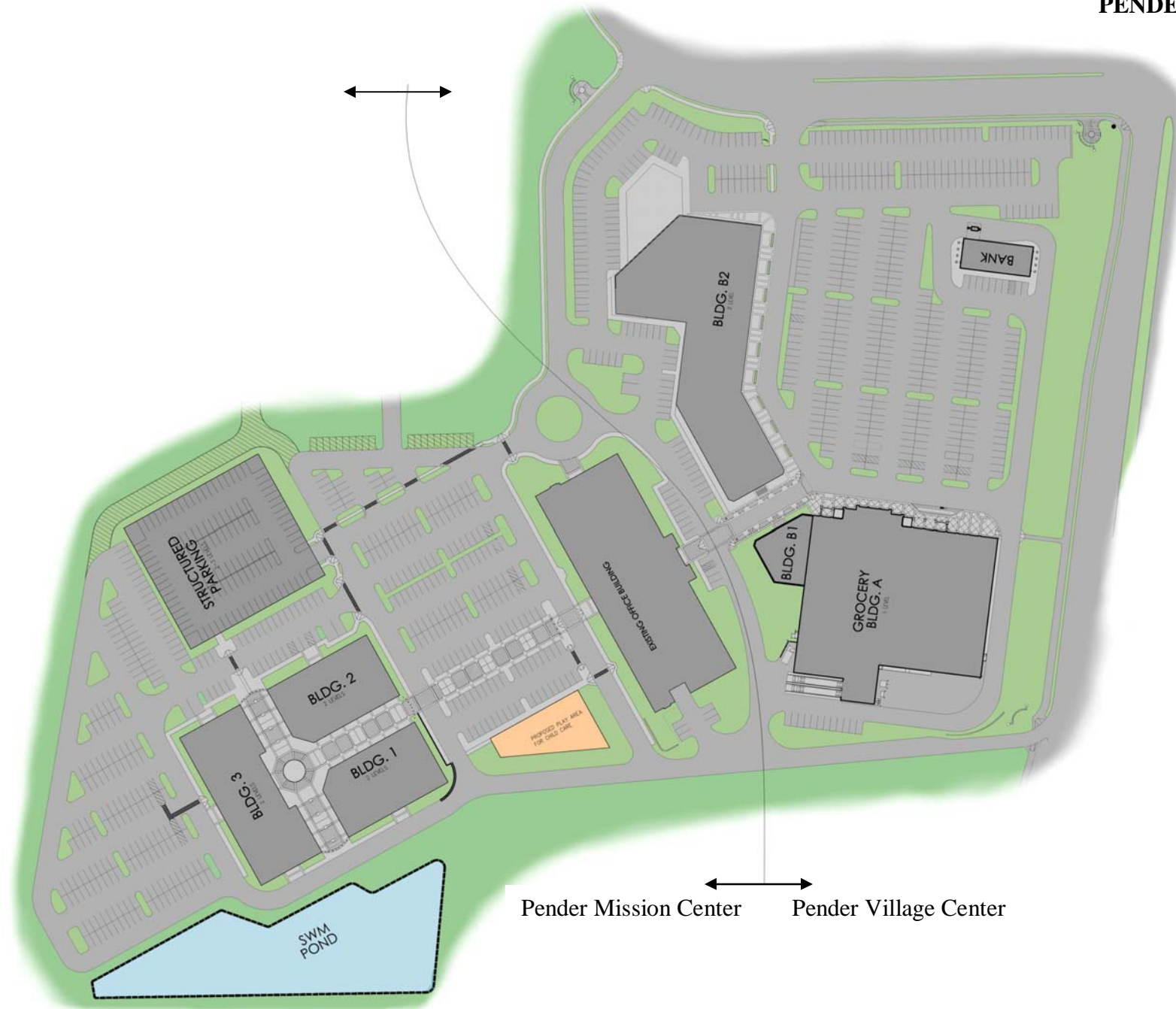

Pender Mission Center Pender Village Center

Pender Village Center and Mission Center Logos









To create a sense of unity in the Pender Village Center and the Pender Mission Center, a consistent logo type has been created. There are several iterations of the logo used to create a cohesive look while still maintaining flexibility to accommodate varying formats. It will be used on entrance signs and other monument signs to create a sense of entering. It will also be used throughout the Centers as branding to create a sense of community and identity in the Pender Community. The logo presented here is the preliminary logo. Shape, text, colors and fonts may be modified to reflect future marketing conditions. If the logo is modified, all logos will be changed to maintain the unity of the space. All logos used will be consistent in colors and fonts.













Pender Mission Center

General Provisions

1. The signs shall be built in substantial conformation with the designs illustrated in this sign package, final design changes based on engineering of signs may occur, but will not substantially alter the design.
2. Lighting of signs shall not be blinding, fluctuating or moving.
3. All signs shall comply with applicable requirements of the building codes. No sign shall obstruct required site distances or sight triangles.
4. Notwithstanding the number of signs shown in this package, applicant will not be obligated to construct every sign shown.
5. Sign sizes depicted provide maximum square footage. Sign size may be reduced providing sign is substantially similar to sign depicted
6. This Sign Package does not regulate signage inside of buildings.
7. Tenants are not fixed and any names are shown for illustrative purposes, exact locations and number of tenants are subject to change based on tenant mix.
8. Logos with less than 1 s.f. of area and containing no text may be used throughout the site to help reinforce identity of this planned development without being counted as a sign.
9. Low-lying shrubs, boulder rock massing and/or flowering plants will be provided around the base of permanent monument signs.
10. Building mounted signs provide key identifiers for tenants, and vary in size according to the size of the tenant. Each tenant shall be permitted to install building mounted signage in accordance with the applicable CSP.
11. Building frontage, which is one determinant of the amount of signage available to an individual tenant, is defined to include all building facades for a tenant.
12. All signs shall be fabricated and installed in accordance with the following requirements:
 - (a) The sign lettering of any part or parts thereof shall be located within the physical limits of the sign area.
 - (b) All signs shall be fabricated and installed in compliance with all applicable codes. All signs shall have appropriate UL stickers attached to the top of each letter.
 - (c) Signage shall not come within 1 foot 6 inch spacing of the end of individual demising frontage, so as not to encroach on adjacent tenant signs.
13. Painting or printing signs on the exterior surface of any building shall be prohibited except small scale signs relative to store name, address and stating store hours which are neatly lettered on the glass of the storefront, subject to landlord's approval. In addition, any non-customer door for receiving merchandise may have signage in 2-inch block letters, which identifies the tenant.

RETAIL & OFFICE SIGNAGE FOR PENDER VILLAGE CENTER & PENDER MISSION CENTER								
Type of Sign	Sec.12 - Zoning Ordinance	PROPOSED						
		Symbol for Sign	Sign Use	Description of Sign	Max SF of Sign	Letter/Logo Size	Mounting Height Range	Letter / Logo Face/Edge Color
Monument Signs	Sec. 12-205 (3) 80 SF maximum 1 sign		Pender Village Center Sign (Primary)	Backlit Panel signs mounted on EIFS Background, with Stone Base, ground mounted lights	208 SF	Panel height is 1'-10" per tenant, 5 panels	Overall sign is 16'-0" in height, Panels are 1'-10" in height	White letters on medium dark panel
			Pender Village Center Sign (Secondary)	Backlit Panel signs mounted on EIFS Background, with Stone Base, ground mounted lights	118 SF	Panel height is 1'-5" per tenant, 5 panels	Overall sign is 12'-0" in height, Panels are 1'-5" in height	White letters on medium dark panel
			Pender Mission Center Sign	Pin Mounted letters on brick or hardiboard background, with stone accents, ground mounted lights	42 SF	1'-3" letter height	Overall sign is 3'-0" in height	Gold or Green pin mounted letters, Black edge
Directional Signage	Sec. 12-203 (13 C) 15 SF maximum each		Pender Directional Signs (Primary)	Routed letters on Hardiboard mounted on Stone Base, ground mounted lights	15 SF	varies	Overall sign is 4'-0" in height	White letters on green panel
			Pender Directional Signs (Secondary)	Routed letters metal mounted on Stone Base, no illumination	approx. 4 SF	varies	Overall sign is 2'-6" in height	White letters on dark panel
Blade Signs	not addressed in ordinance		Retail Blade Signs Canopy Mounted	Wooden or Metal Blade signs with Tenant Name & PVC logo (optional), no Tenant logos allowed; single color	5 SF maximum; 1 Sign/Tenant	4" letter height	Mounted under canopy	Gold PMS 7406, Green PMS 5545 edge/material
			Retail Blade Signs Cantilever Mounted	Wooden or Metal Blade signs with Tenant Name & PVC logo (optional), no Tenant logos allowed; single color	5 SF maximum; 1 Sign/Tenant	4" letter height	Mounted under canopy	Gold PMS 7406, Green PMS 5545 edge/material
Building Mounted Tenant Signs	Sec. 12-203 (8) 295 SF maximum		Anchor Tenant Signs (Building A)	Channel Letters on Raceway, lit box tagline, individual logos; raceway to match bldg exterior	426 SF distributed across multiple signs	varies, 3'-6" letter height; logo height 4'-0"	Below roof line	Varies; Black edge





RETAIL & OFFICE SIGNAGE FOR PENDER VILLAGE CENTER & PENDER MISSION CENTER								
Type of Sign	Sec.12 - Zoning Ordinance	PROPOSED						
		Symbol for Sign	Sign Use	Description of Sign	Max SF of Sign	Letter/Logo Size	Mounting Height Range	Letter / Logo Face/Edge Color
Building Mounted Tenant Signs	Sec. 12-203 (9) 200 SF maximum per tenant, included in totals below		Building B1 & B2 Major Retail Tenant Signs	Individual internally illuminated channel letters with Plexiglas face lens mounted on building façade on raceway to match bldg	75 SF maximum, per tenant included in totals below	3'-6" letter height; logo height 4'-0"	Below roof line	Varies; Black edge
	Sec. 12-203 (9) 125 SF maximum for bldg		Building B1 Retail Tenant Signs	Individual internally illuminated channel letters with Plexiglas face lens mounted on building façade on raceway	180 SF total for building, 60 SF maximum per tenant	2'-0" letter height, logo height 3'-0"	Below roof line	Varies; Black edge
	Sec. 12-203 (9) 1020 SF maximum for bldg		1st Flr Retail Tenant Signs Building B2	Individual internally illuminated channel letters with Plexiglas face lens mounted on building façade on raceway	1500 SF total for building, 60 SF maximum per tenant	2'-0" letter height, logo height 3'-0"	Below roof line	Varies; Black edge
Building Mounted Tenant Signs	Sec. 12-203 (8) 731 SF maximum for bldg		2nd Floor Office Tenant Signs Building B2	Individual internally illuminated channel letters with plexiglass face lens mounted on building façade on raceway to match bldg; rear tenants will be allowed sign area on frontage	900 SF total for building, 60 SF maximum per tenant	1'-6" letter height, logo height 3'-0"	Below roof line	Varies; Black edge
	Sec. 12-203 (9) 200 SF maximum per tenant included in total above		Major Office Tenant Signs (2nd Flr) Building B2	Individual internally illuminated channel letters with plexiglass face lens mounted on building façade on raceway to match bldg	75 SF maximum per tenant , included in total above	3'-6" letter height; logo height 4'-0"	Below roof line	Varies; Black edge

RETAIL & OFFICE SIGNAGE FOR PENDER VILLAGE CENTER & PENDER MISSION CENTER								
Type of Sign	Sec.12 - Zoning Ordinance	PROPOSED						
		Symbol for Sign	Sign Use	Description of Sign	Max SF of Sign	Letter/Logo Size	Mounting Height Range	Letter / Logo Face/Edge Color
Office Entrance and Building Address Identification	not addressed in ordinance		Office Entrance and Building Address Identification Sign (Building B2)	Individual pin mounted letters, letters painted on Fabric Canopy or Fabric Awning and/or Individual internally illuminated channel letters with plexiglass face lens mounted on building façade on raceway to match bldg	100 SF total	Varies; See Page 27	Below roof line	Varies; Black edge
Building Mounted Tenant Signs	Sec. 12-203 (8) 135 SF maximum		Pad Building (Bank)	Individual internally illuminated channel letters with plexiglass face lens mounted on building façade on raceway to match bldg	approx. 150 SF	1'-6" letter height	Below roof line	Varies; Black edge
Building Mounted Tenant Signs	Sec. 12-203 (8) 365 SF maximum		3901 Fair Ridge Drive (Existing Office Bldg)	Individual internally illuminated channel letters with plexiglass face lens mounted on building façade on raceway to match bldg. Pin mounted, non-illuminated building address sign.	370 SF total, 4 tenant signs maximum at 90 SF each, plus 10 SF (max.) for building address.	1'-8" letter height, logo height 2'-6"	Below roof line	Varies; Black edge
Building Mounted Tenant Signs	Sec. 12-203 (8) 670 SF max for 3 bldgs Bldg 1 = 270 SF Bldg 2 = 200 SF Bldg 3 = 200 SF		Office Building (Bldgs 1, 2, 3)	Individual pin mounted letters, solid, uniform font & color, no illumination	30 SF maximum per tenant; tenant layout is not currently available	1'-6" letter height, logo height 2'-6"	Below roof line	Black; Black edge
			Major Tenant Office Building (Bldgs 1, 2, 3)	Individual pin mounted letters, solid, uniform font & color, no illumination	120 SF total, 2 major tenant signs per building, 60 SF maximum per tenant	3'-0" letter height, logo height 3'-6"	Below roof line	Black; Black edge
Misc. Signs	no maximum SF noted in Ordinance		Seasonal Banners on Light Poles	Screen printed fabric of metal panels mounted on light poles	18 SF per banner	N/A	17'-6" to 25'-0"	Varies
	not addressed in ordinance		Informational Signs	Stop, Yield, etc.	In conformance with VDOT/state & federal standards	N/A	In conformance with VDOT/state & federal standards	In conformance with VDOT/state & federal standards

Monument Signs

A hierarchy of monument signs for Pender has been developed to correspond to the hierarchy of entrance points and directional information. Substantial ground mounted signs denote key entrances while secondary entrances are marked with signs that are smaller but of a consistent design type.

Directional signs to assist in general flow through the site are designed to be visually legible at a larger range, while signs intended to direct smaller traffic patterns such as parking areas or movement through the drive-through bank teller, are smaller for more concise instruction. The plan shows probable locations for these signs. Locations are subject to change due to final design and engineering requirements. Because of the fluctuations in design and market conditions, flexibility is needed to relocate directional signs for future leasing conditions; directional sign locations may be modified by the Fairfax County Department of Planning and Zoning so long as they are in substantial conformance with the applicable CSP.

-  Pender Village Center Sign (Primary)
-  Pender Village Center Sign (Secondary)
-  Pender Mission Center Sign
-  Pender Directional Sign (Primary)
-  Pender Directional Sign (Secondary)

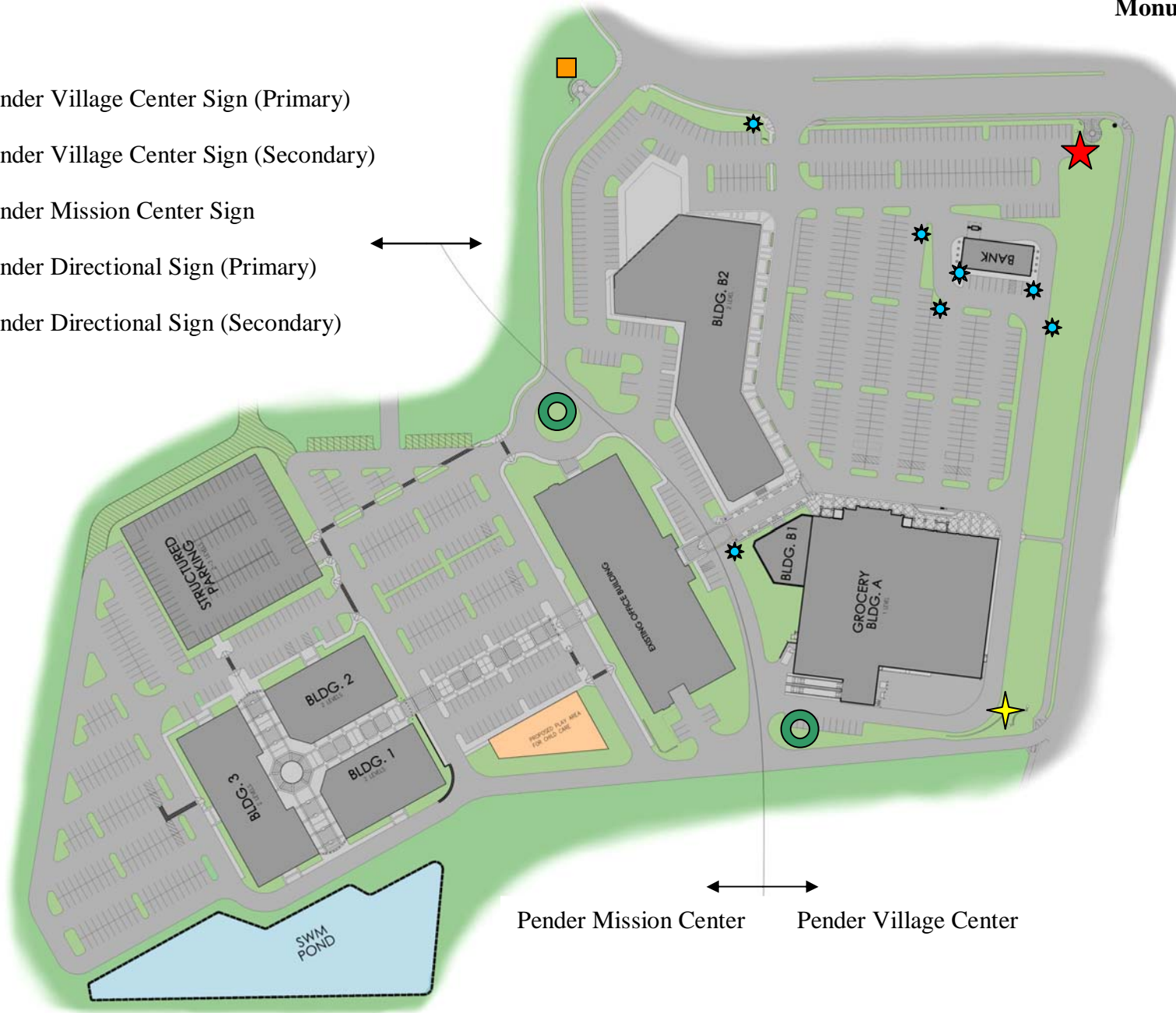

Pender Mission Center Pender Village Center

★ **Pender Village Center Sign (Primary):**

This monument sign marks the entrance at the corner of Lee Jackson Memorial Hwy and Fair Ridge Drive. It displays the names of major tenants in order to provide visibility to vehicular traffic. The entrance feature may incorporate the name and logo of the center. It will be illuminated internally.

DESCRIPTION:

Panel signs mounted on EIFS background with stone base
208 S.F. max sign area

GRAPHICS / LETTERING

- White letters (reveal) on Medium dark panel cutout
- Logo mounted to EIFS, backlit
- Corporate logos allowed
- 1' – 10" Sign Bands
- Internal Illumination

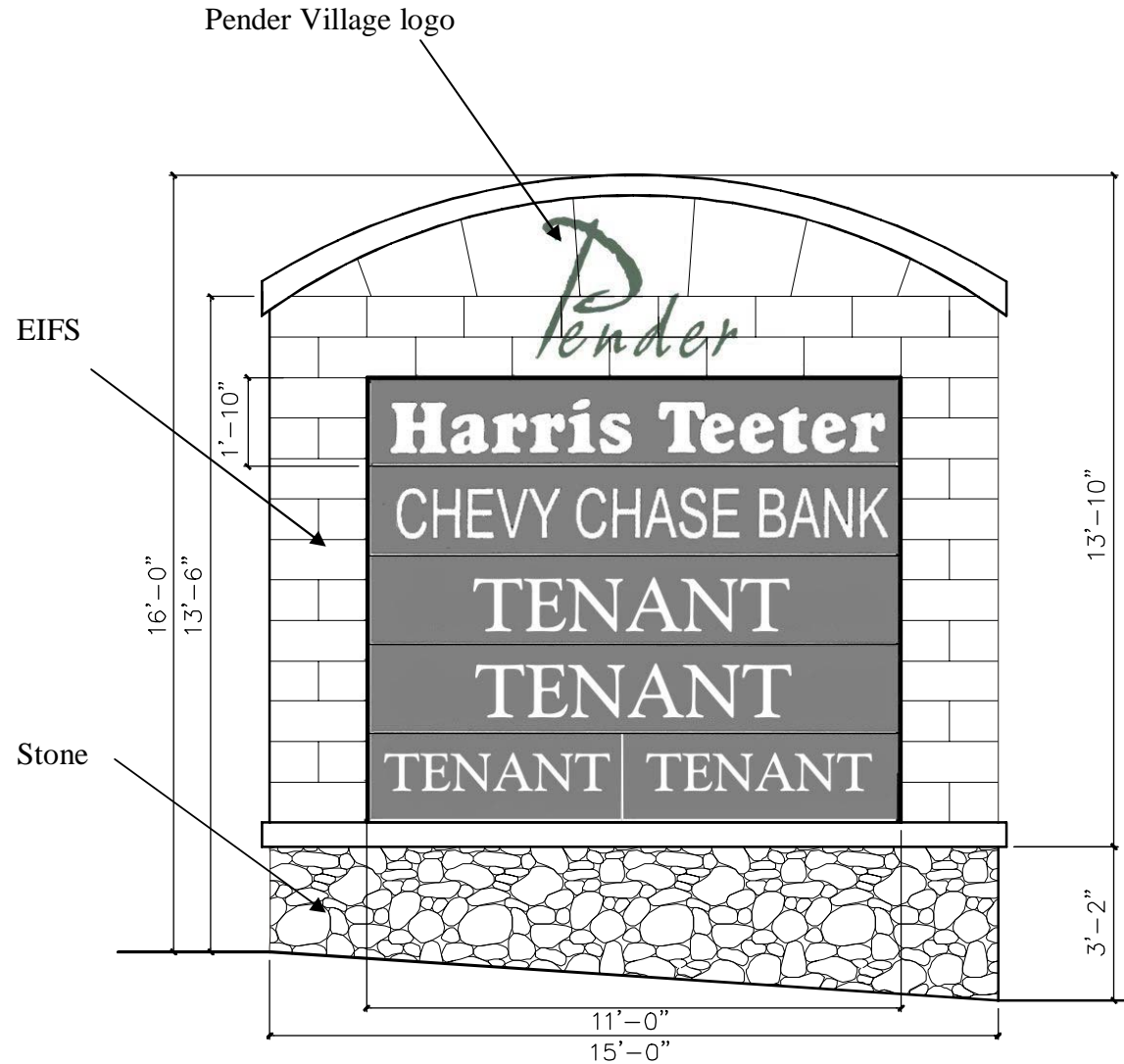

■ **Pender Village Center Sign (Secondary):**

This monument sign marks the entrance on Fair Ridge Drive. It displays tenant names for vehicular traffic approaching the center from the North. The entrance feature may incorporate the name and logo of the center. It will be illuminated internally.

DESCRIPTION:

Panel signs mounted on EIFS background with stone base
118 S.F. max sign area

GRAPHICS / LETTERING

White letters (reveal) on Medium dark panel cutout

Logo mounted to EIFS, backlit

Corporate logos allowed

1' – 5" Sign Bands

Internal Illumination

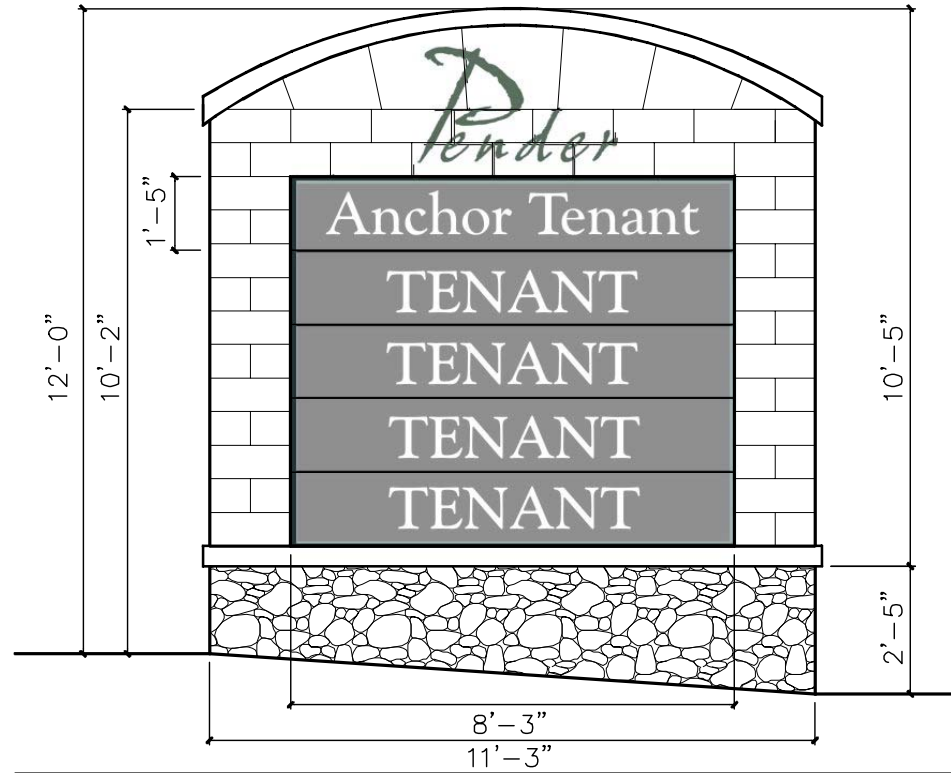

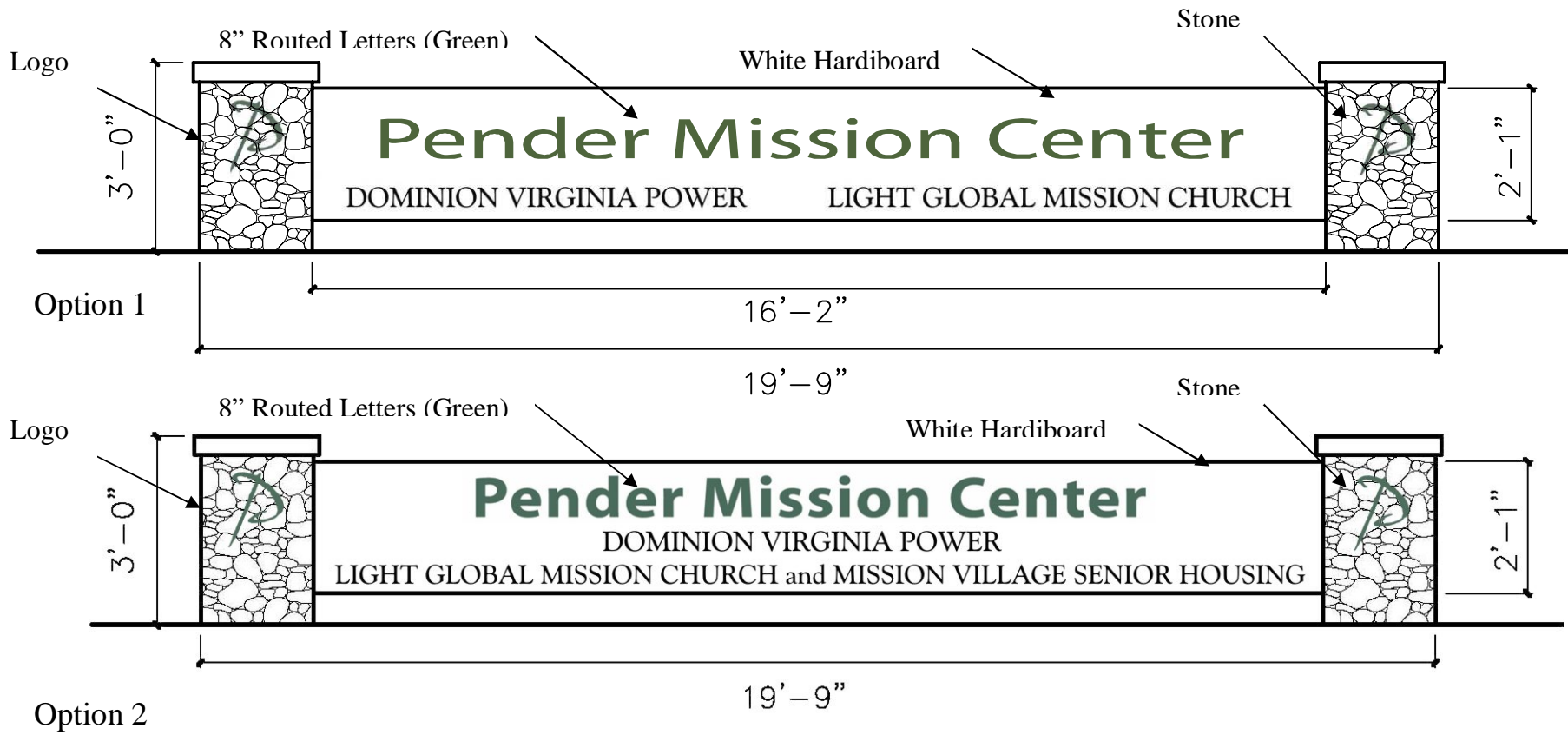

★ **Pender Mission Center Sign:**

The Mission Center sign marks the entrance to the office portion of the center. It displays the name of the center and the names of major tenants. The sign will have ground mounted spot lighting.

DESCRIPTION:

- Option 1 Letters routed in Hardiboard background
- Option 2 Letters routed in Hardiboard background
- 42 S.F. max sign area

GRAPHICS / LETTERING
 Font: Grimshaw Hand, Myriad Pro
 Letter Height: 1'0" max

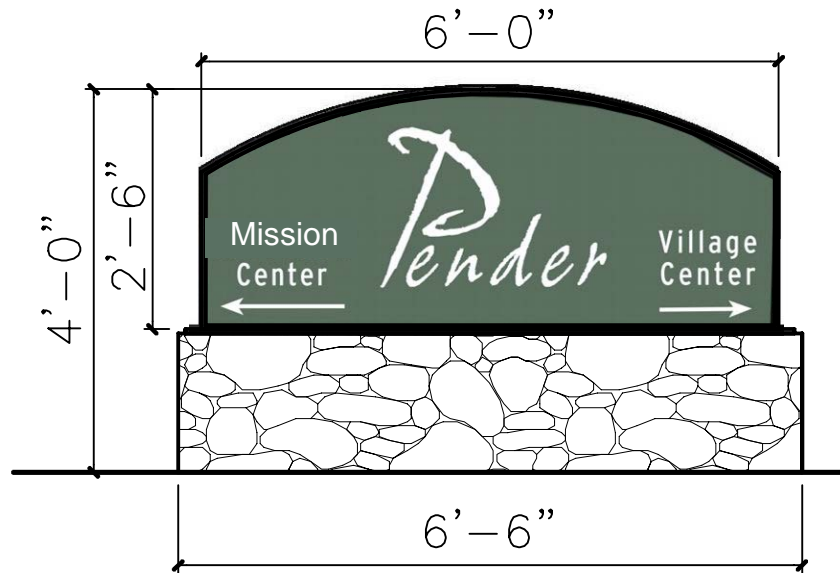

Pender Directional Signs (Primary):

Directional Signs are located within the center to assist in general vehicular flow through the site. They direct customers and visitors to the shopping or office portions of the center. Signs will have internal illumination.

DESCRIPTION:

Letters routed in Hardiboard background mounted on stone base

Max height of sign 4'

Landscaping / Planting around sign

15 S.F. max sign area

GRAPHICS / LETTERING

Font: Grimshaw Hand, Myriad Pro

★ **Pender Directional Signs (Secondary):**

The secondary directional signs direct smaller traffic patterns such as parking areas or movement through the drive-through bank teller.

DESCRIPTION:

Metal Sign Faces and Sides

Max height of sign 2' - 6"

No Illumination

4 S.F. max sign area

GRAPHICS / LETTERING

Font: Grimshaw Hand, Myriad Pro

All copy and arrows to be high performance white vinyl

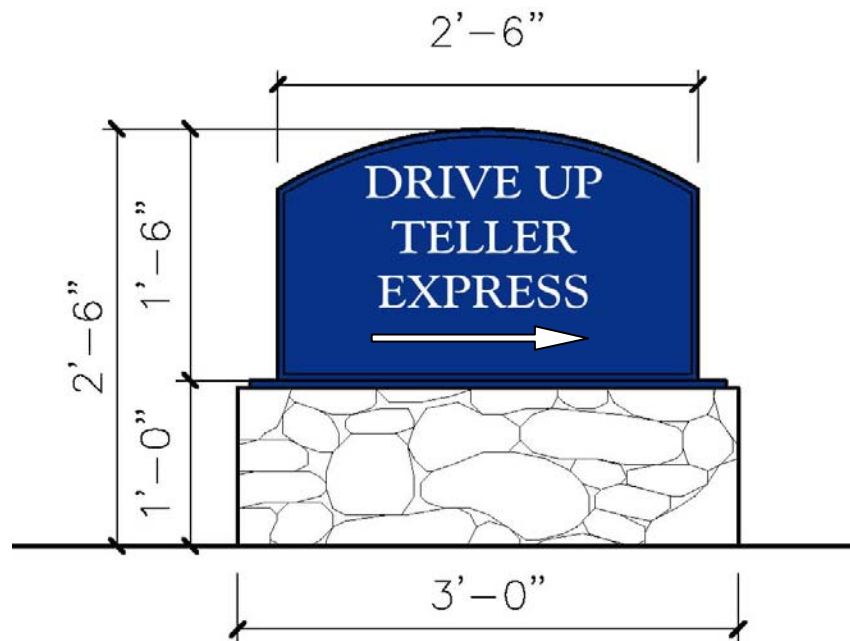

Tenant Signs

Pender Sign Guidelines



Anchor Tenant Signs Bldg A

Major Office Tenant B2

Major Tenant B1, B2

Tenant B1, B2

Office Tenant B2

Existing Office Building Signs

Office Building Signs

Pad Building Signs

Retail Blade Signs

Office Entrance and Building Address Identification

All sides

All sides

All sides

Two sides

Tenant Signs

All sides



Comparison of Tenant Sign Sizes:



Diagram of an Anchor Tenant Sign. The word "ANCHOR" is shown in a large, bold, serif font. A vertical dimension line on the left indicates a maximum height of 3'-0" MAX.

Anchor Tenant Sign (Building A)



Diagram of an Office Tenant Sign (B2). The word "TENANT" is shown in a serif font. A vertical dimension line on the left indicates a height of 1'-6". A horizontal dimension line above the word indicates a width of 1'-6".

Office Tenant Signs (B2)
Pad Building
Office Building (1,2,3)



Diagram of a sign for 3901 Fair Ridge Drive Office Building. The word "TENANT" is shown in a serif font. A vertical dimension line on the left indicates a height of 1'-8". A horizontal dimension line above the word indicates a width of 1'-6".

3901 Fair Ridge Drive
Office Building



Diagram of a Retail Tenant Sign (B1 & B2). The word "TENANT" is shown in a serif font. A vertical dimension line on the left indicates a height of 2'-0". A horizontal dimension line above the word indicates a width of 1'-6".

Retail Tenant Signs (B1 & B2)

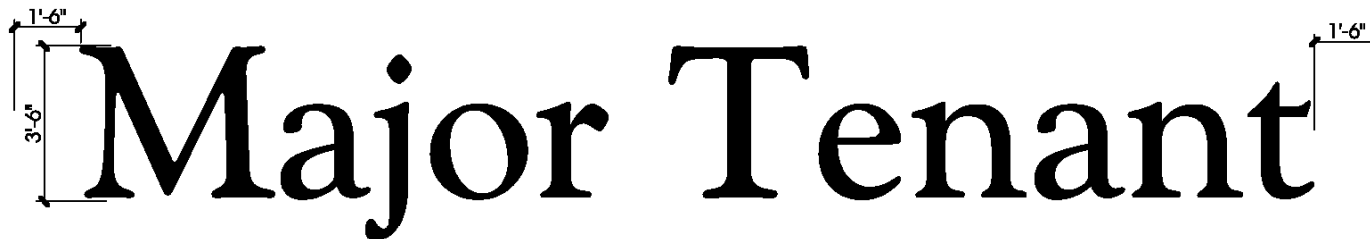

Diagram of a Major Tenant sign. The words "Major Tenant" are shown in a large, bold, serif font. A vertical dimension line on the left indicates a height of 3'-6". A horizontal dimension line above the word "Major" indicates a width of 1'-6". A horizontal dimension line above the word "Tenant" indicates a width of 1'-6".

Major Retail Tenant (Building B1 & B2) and Office Tenant (Building B2) Signs

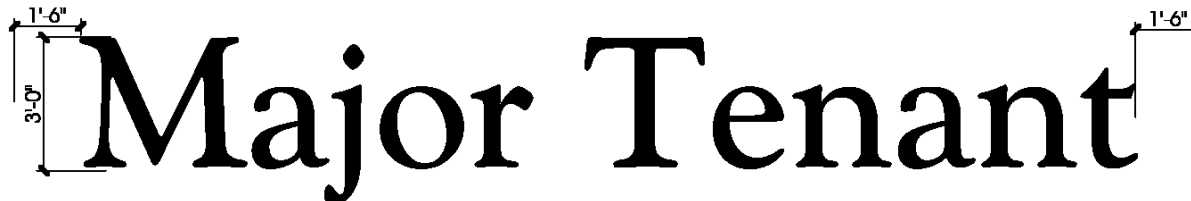

Diagram of a Major Tenant Office Building sign. The words "Major Tenant" are shown in a large, bold, serif font. A vertical dimension line on the left indicates a height of 3'-0". A horizontal dimension line above the word "Major" indicates a width of 1'-6". A horizontal dimension line above the word "Tenant" indicates a width of 1'-6".

Major Tenant Office Building (Buildings 1,2,3)

More than one line of text may be used so long as the total height of the lines together does not exceed the maximum height allowed.



Front Elevation

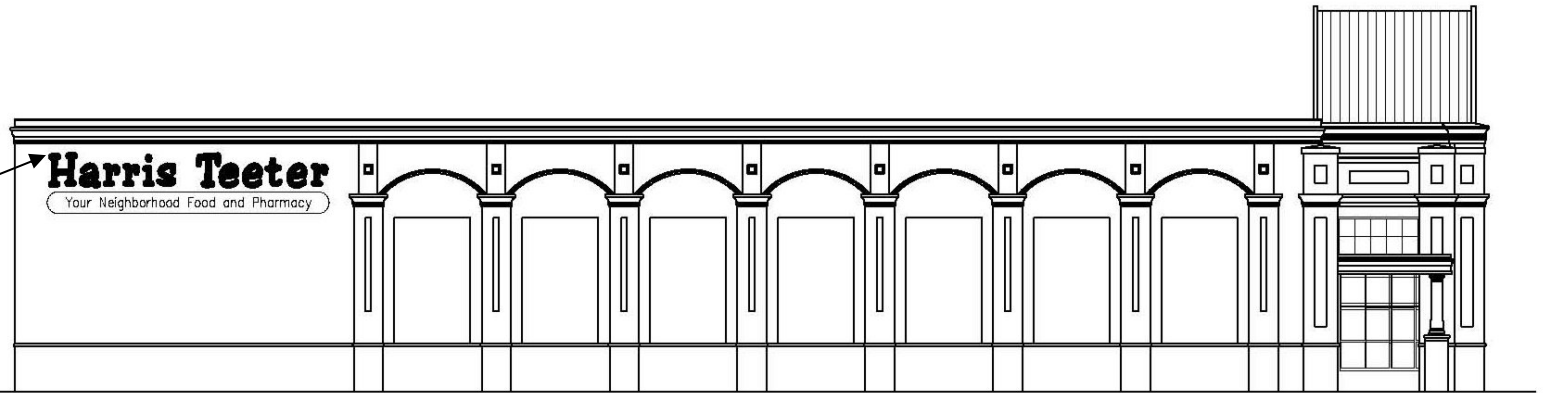

★ Channel Letter Sign

Side Elevation

Anchor Tenant Signs (Building A)

Tenants signs depicted reflect current leasing conditions. However, tenant may change and therefore signs are subject to modification as marketing trends prevail. Tenant will have the availability to display illuminated signs behind storefront glass.

★ Harris Teeter

Your Neighborhood Food & Pharmacy

★ Anchor Tenant Signs (Building A) Type 1:

DESCRIPTION:

Channel Letters on Raceway

Lighted box Tagline signs

1.5 sq. ft. per linear ft of frontage

The total amount of signage can be allotted where it best directs, advertises and informs.

GRAPHICS / LETTERING

Tenant Logos allowed

Size 42" x 30' 85 sq. ft.

Tagline Size 2'-6" x 27'-9" 69.5 sq. ft.

★ Pharmacy

Anchor Tenant Signs (Building A) Type 2:

DESCRIPTION:

Channel Letters on Raceway

GRAPHICS / LETTERING

Size 1'6" x 12'-0" 18 sq. ft.

★ Open 24 Hours

Anchor Tenant Signs (Building A) Type 3:

DESCRIPTION:

Channel Letters on Raceway

GRAPHICS / LETTERING

Size 1'6" x 16'-0" 24 sq. ft.



★ Anchor Tenant Signs (Building A) Type 4:

DESCRIPTION:

Open face channel letter on raceway

GRAPHICS / LETTERING

Tenant logo

Size 5'-0" x 7'-0" 35 sq. ft.



★ Anchor Tenant Signs (Building A) Type 5:

DESCRIPTION:

Sign Box

GRAPHICS / LETTERING

Size 2' Diameter

4 sq. ft.

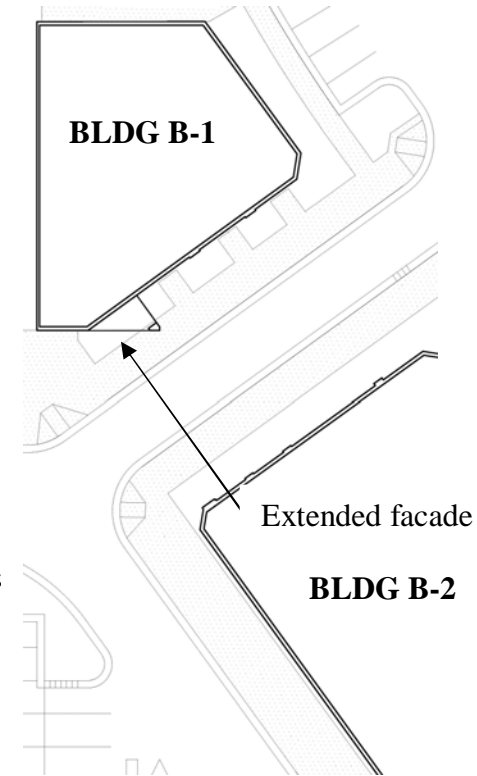

Building B1 Retail Tenant Signs:

The positioning of building B-1 in relationship to B-2 limits visibility of the side tenant’s signage so there is a signage feature to display the signs for those tenants whose signage is less visible. This allows customers to approach from the primary parking field and directs them to the stores they are interested in visiting.

DESCRIPTION:

Channel Letters with interior illumination on raceway
 18” from Tenant demising walls
 Signs may be dispersed in varying configurations
 The total amount of signage can be allotted where it best directs, advertises and informs. Therefore signage for tenants whose visibility is limited will be given signage on more visible signage feature.

- ★ **RETAIL TENANT**
 Tenant Logos allowed max height 3’-0”
 Letter Height: 2’-0”
 60 SF maximum sign area
- ⊙ **MAJOR RETAIL TENANT-** (a major retail tenant is defined as a tenant that occupies 3500 or more SF on the first floor of either buildings B1 or B2)
 Letter Height: 3’ 6”
 Logo height: 4’-0”
 75 SF maximum sign area



1st Floor Retail Tenant Signs (Building B2):

DESCRIPTION:

Channel Letters with interior illumination on raceway
 18" from Tenant demising walls
 Signs may be dispersed in varying configurations
 The total amount of signage can be allotted where it best directs, advertises and informs.



RETAIL TENANT

Tenant Logos allowed max height 3'-0"
 Letter Height: 2'-0"
 60 SF maximum sign area



MAJOR RETAIL TENANT - (a major retail tenant is defined as a tenant that occupies 3500 or more SF on the first floor of either buildings B1 or B2)

Letter Height: 3' 6" max
 Logo height: 4'-0"

75 SF maximum sign area (may be comprised of several signs on either the 1st or 2nd floor, but not on the same facade)



2nd Floor Office Tenant Signs (Building B2):

DESCRIPTION:

Channel Letters with interior illumination on raceway
 18" from Tenant demising walls
 Signs may be dispersed in varying configurations
 The total amount of signage can be allotted where it best directs, advertises and informs.



OFFICE TENANT

Tenant Logos allowed max height 3'-0"
 Letter Height: 18"
 60 SF maximum sign area



MAJOR OFFICE TENANT - (a major office tenant is defined as a tenant that occupies 3500 or more SF on the second floor of building B2)

Letter Height: 3' 6"
 Logo height: 4'-0"
 75 SF maximum sign area

Office Entrance and Building Address Identification Sign (Building B2):

DESCRIPTION:

Individual pin mounted letters, letters painted on Fabric Canopy or Fabric Awning and/or Individual internally illuminated channel letters with plexiglass face lens mounted on building façade on raceway to match bldg

GRAPHICS / LETTERING

Font: Goudy
 Color: Multiple Colors
 Letter Height: 3'-0"
 Logo height: 3'-6"
 100 SF maximum sign area

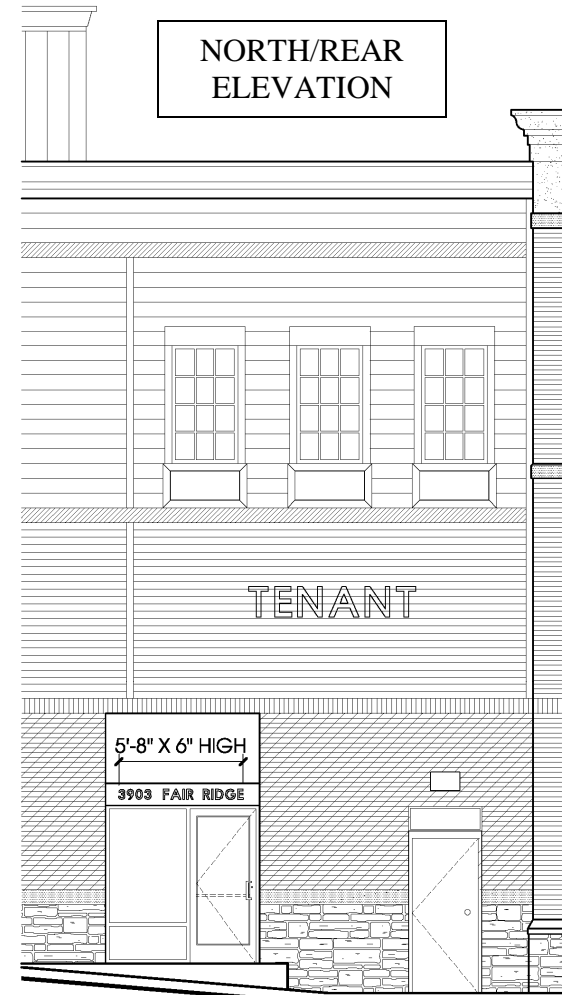

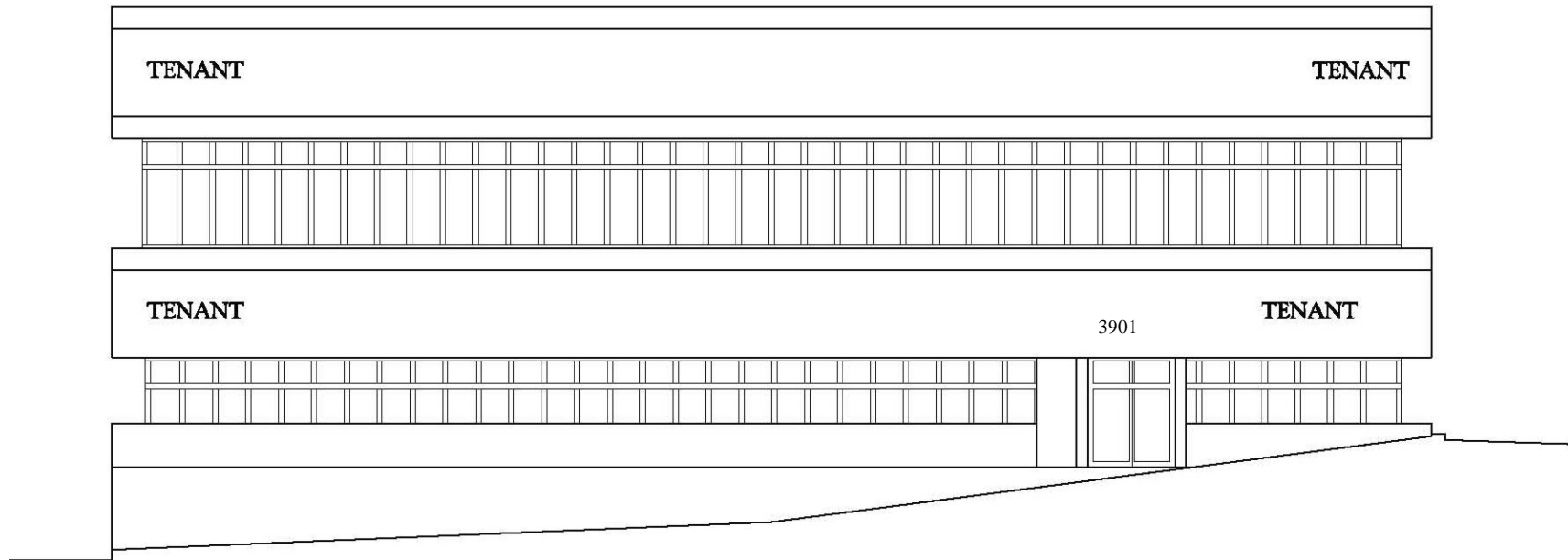

*** 3901 Fair Ridge Drive (Existing Office Building):**

DESCRIPTION:

Interior Illuminated Channel Letters on Raceways
Signs may be dispersed in varying configurations
1.5 S.F. per linear ft of frontage
Main Entrances Building Address- Individual
pin-mounted letters, or letters painted on canopy,
solid, uniform font & color, no illumination, not to exceed 10 SF.

GRAPHICS / LETTERING

Font: Goudy
Color: Multiple Colors
Letter Height: 1'-8"
Logo height: 2'-6"
4 tenant signs per building
Tenant Signs - 90 SF maximum



▲ **Office Building (Buildings 1, 2, and 3):**

DESCRIPTION:

Pin Mounted (non illuminated) signs
Signs may be dispersed in varying configurations
Font: Goudy
Color: Black

TENANT:

30 SF maximum sign area
Letter Height: 18"
Tenant Logos allowed 30" height Max

MAJOR TENANT (A major office tenant is defined as a tenant occupying 5,000 or more SF of buildings 1, 2, or 3.)

Letter Height: 3'-6"
Logo Height: 3'-6"
60 SF maximum sign area

■ **Pad Building (Bank):**

Tenant signs depicted reflect current leasing conditions. However tenant may change and therefore signs are subject to modification as marketing trends prevail.

DESCRIPTION:

Channel Letters with interior illumination

Signs may be dispersed in varying configurations (for example 37.5 sq ft on each of 4 sides, or 75 sq ft on each of 2 sides)

150 S.F. of building mounted signage (not to exceed 1.5 S.F. per linear ft of frontage on street faces), and additional incidental directional signs and ATM signage not to exceed 50 S.F. will be allowed for the pad building.

The total amount of signage can be allotted where it best directs, advertises and informs.

GRAPHICS / LETTERING

Font and color: Tenant logos and color schemes allowed

Letter Height: Up to 24" high if signs are limited to two sides of the building

Up to 18" high if signs are on more than two sides of the building



PROPOSED INDIVIDUALLY MOUNTED 18" CHANNEL LETTERS AS SHOWN
LETTERS - #2157 RED PLEX. FACES / BLACK SIDE RETURNS / 434U TRIMCAP

FRONT ELEVATION

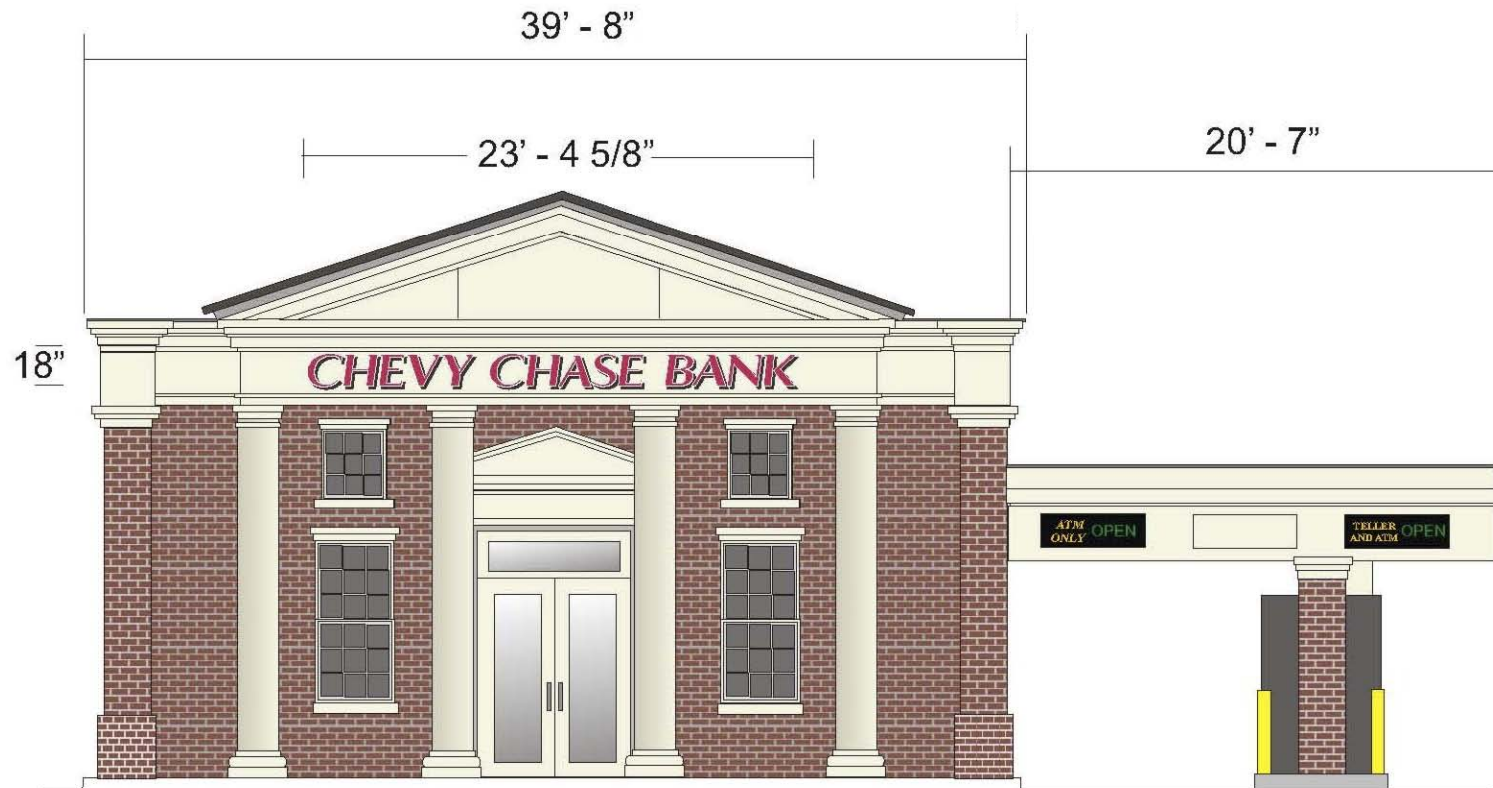

PROPOSED INDIVIDUALLY MOUNTED 18" CHANNEL LETTERS AS SHOWN
LETTERS - #2157 RED PLEX. FACES / BLACK SIDE RETURNS / 434U TRIMCAP

REAR ELEVATION



PROPOSED INDIVIDUALLY MOUNTED 18" CHANNEL LETTERS AS SHOWN
LETTERS - #2157 RED PLEX. FACES / BLACK SIDE RETURNS / 434U TRIMCAP

DRIVE-THRU ELEVATION

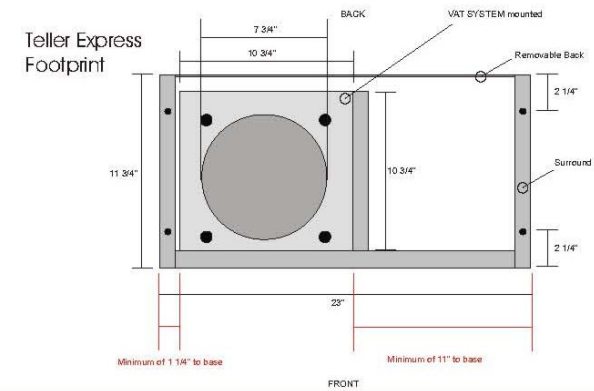
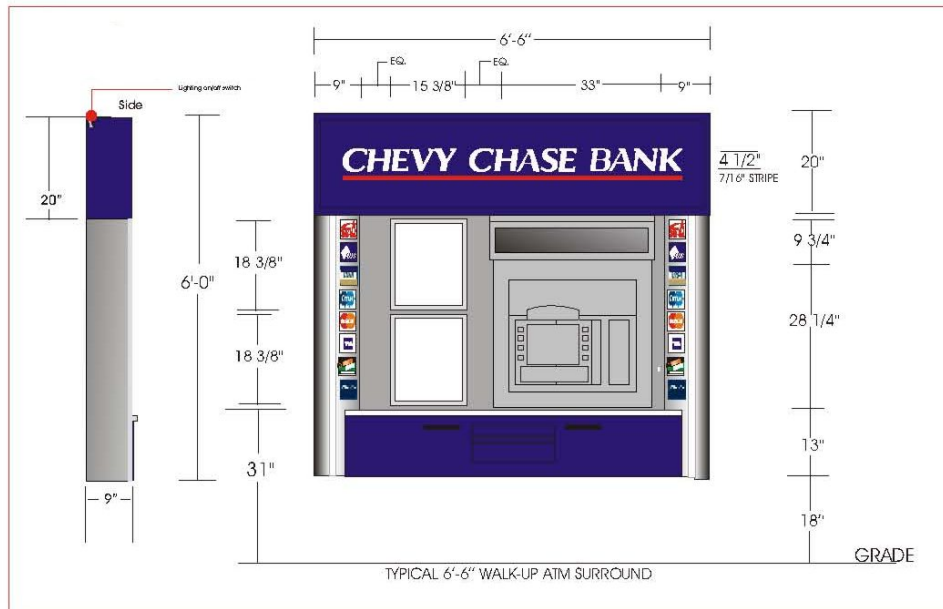

► **Retail Blade Signs (Canopy Mounted):**

Blade signs are used to provide tenant names for pedestrians walking parallel to the building face, who would not have an easily visible view of the tenant signage. These signs are suspended from the canopy above and are located to provide optimal information as the tenant entrances.

DESCRIPTION:

Under Canopy Tenant Sign

- Maximum of 1 sign per tenant (to be installed by Landlord)
- Graphics on 2 sides
- 5 S.F. max
- Single color

Wooden or Metal Blade sign with Painted Tenant Name and Shopping Center Logo (Logo Optional)

Tenant logos not allowed

GRAPHICS / LETTERING:

Lettering: Painted lettering

Letter Height: 4"

Letter Color: Green PMS 5545

Sign Color: Gold 7406

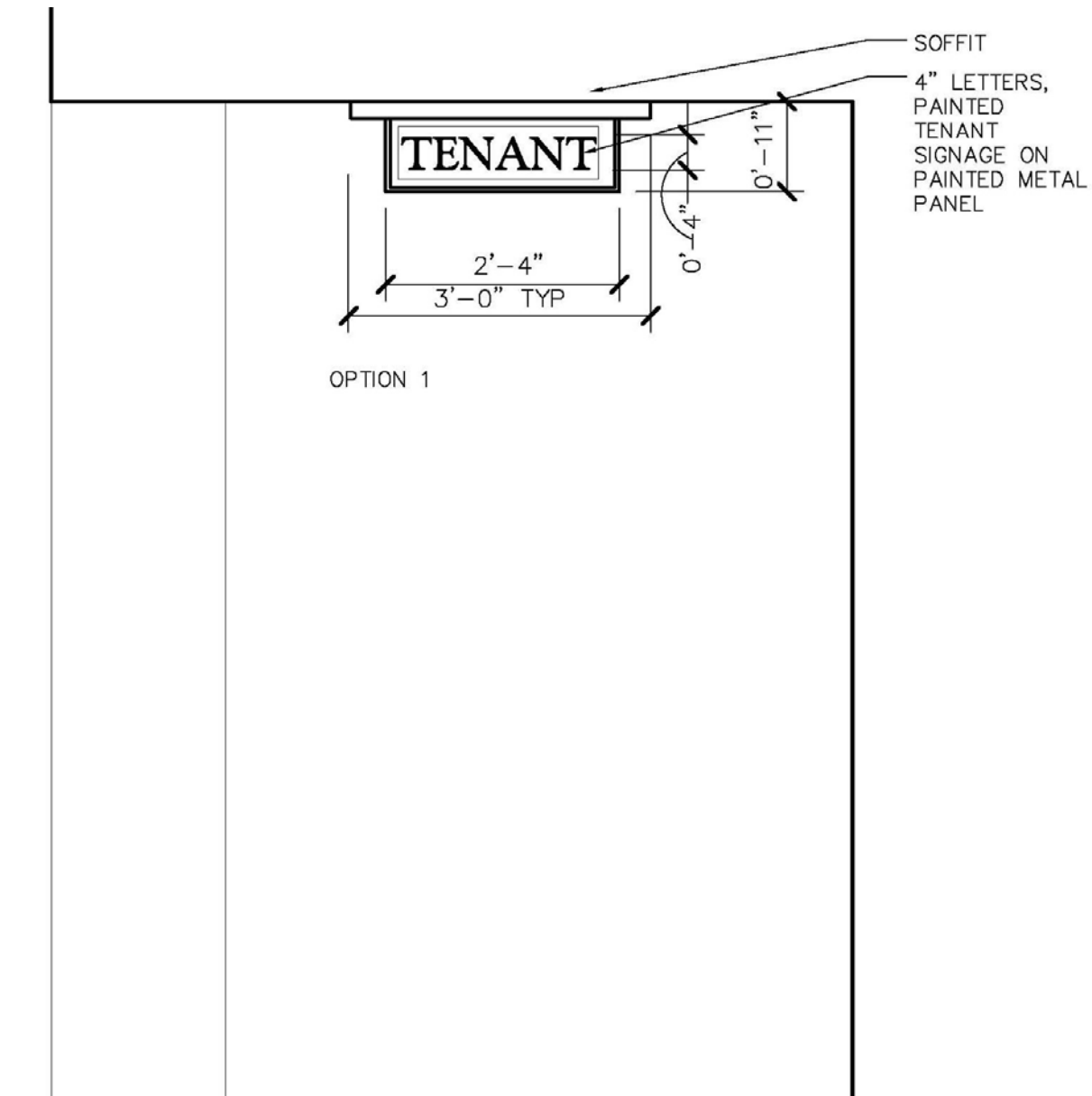

► **Retail Blade Signs (Cantilever Mounted):**

These signs are suspended from the awning above and are located to provide optimal information as the tenant entrances.

DESCRIPTION:

Blade Sign mounted on cantilevering Metal frame.

- Maximum of 1 sign per tenant (to be installed by Landlord)
- Graphics on 2 sides
- 5 S.F. max
- Single color

Wooden or Metal Blade sign with Painted Tenant Name and Shopping Center Logo (Logo Optional)

Tenant logos not allowed

GRAPHICS / LETTERING

Lettering: Painted lettering

Letter Height: 4"

Letter Color: Green PMS 5545

Sign Color: Gold 7406

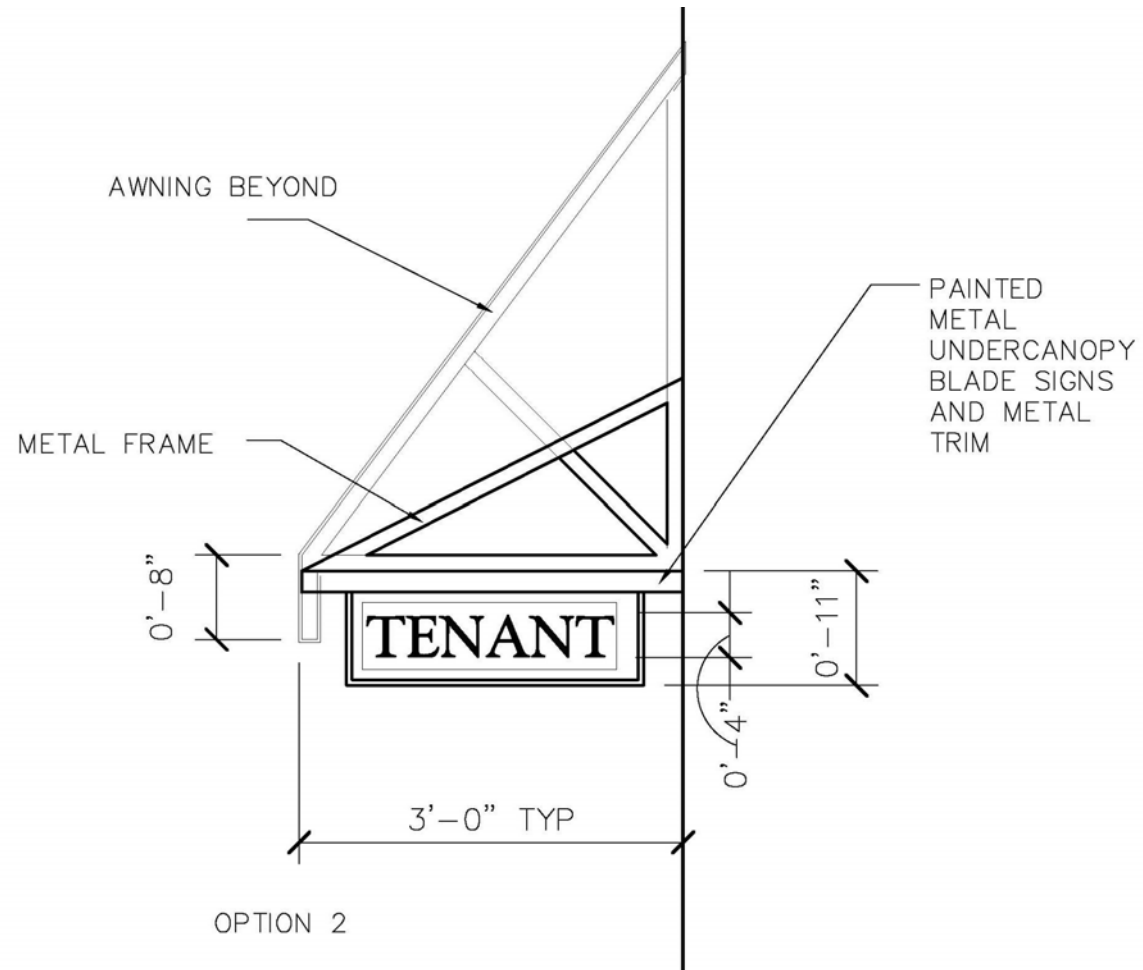

Miscellaneous Signs

Miscellaneous signs are needed throughout the site to provide additional information. Some of these signs mark site amenities such as the parking garage. Others inform about conditions such as the storm water management pond, or provide community spirit through season, and community banners. Because of the fluctuations in design and market conditions, flexibility is needed to relocate signs for future leasing conditions; sign locations may be modified by the Fairfax County Department of Planning and Zoning as long as they are in substantial conformance with the applicable CSP.

Miscellaneous Signs

-  Parking Garage (Vehicular)
-  Parking Garage (Pedestrian)
-  Protected Natural Area
-  Light Pole Banners
-  Historical Marker
-  Flags

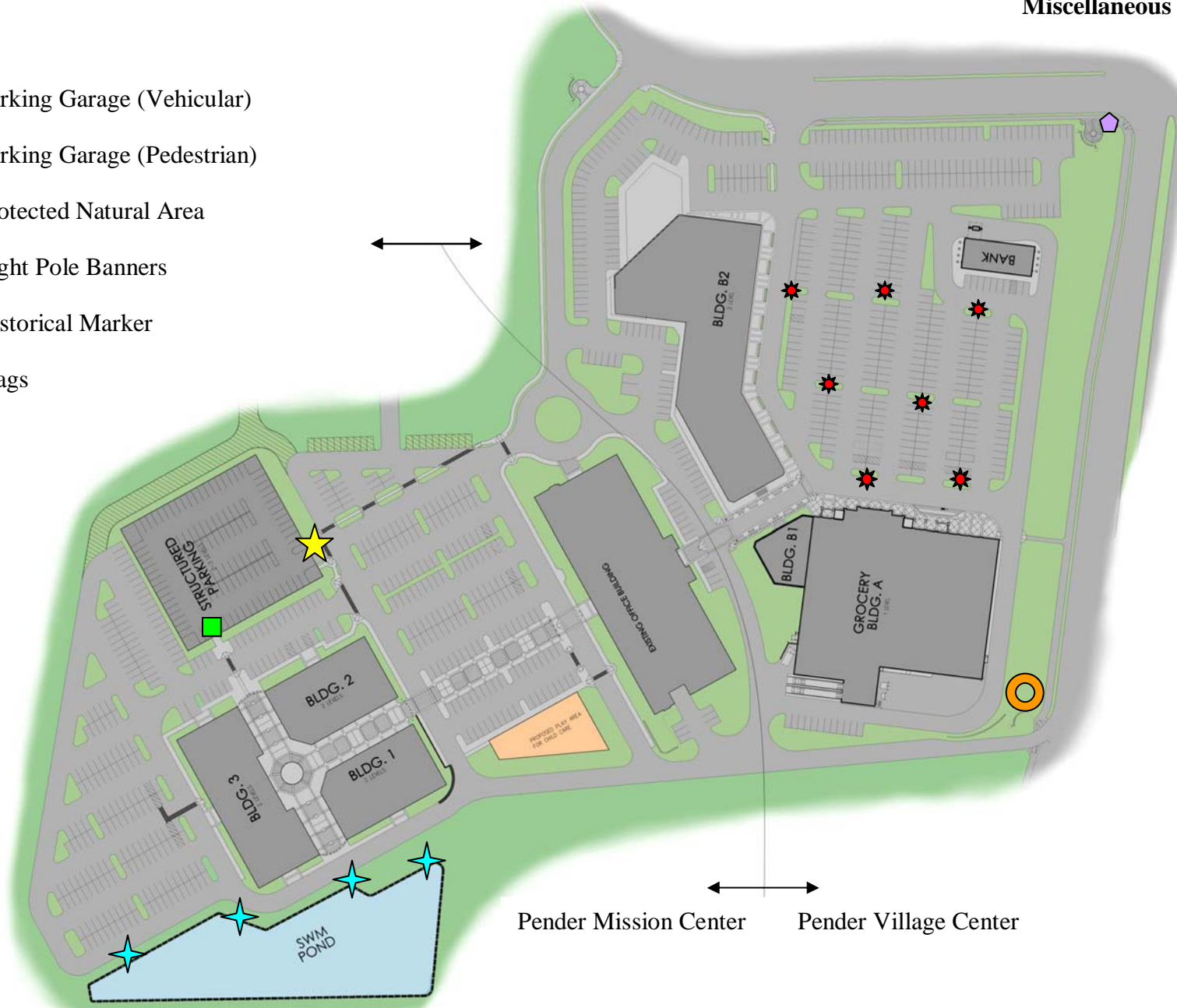

Pender Mission Center Pender Village Center

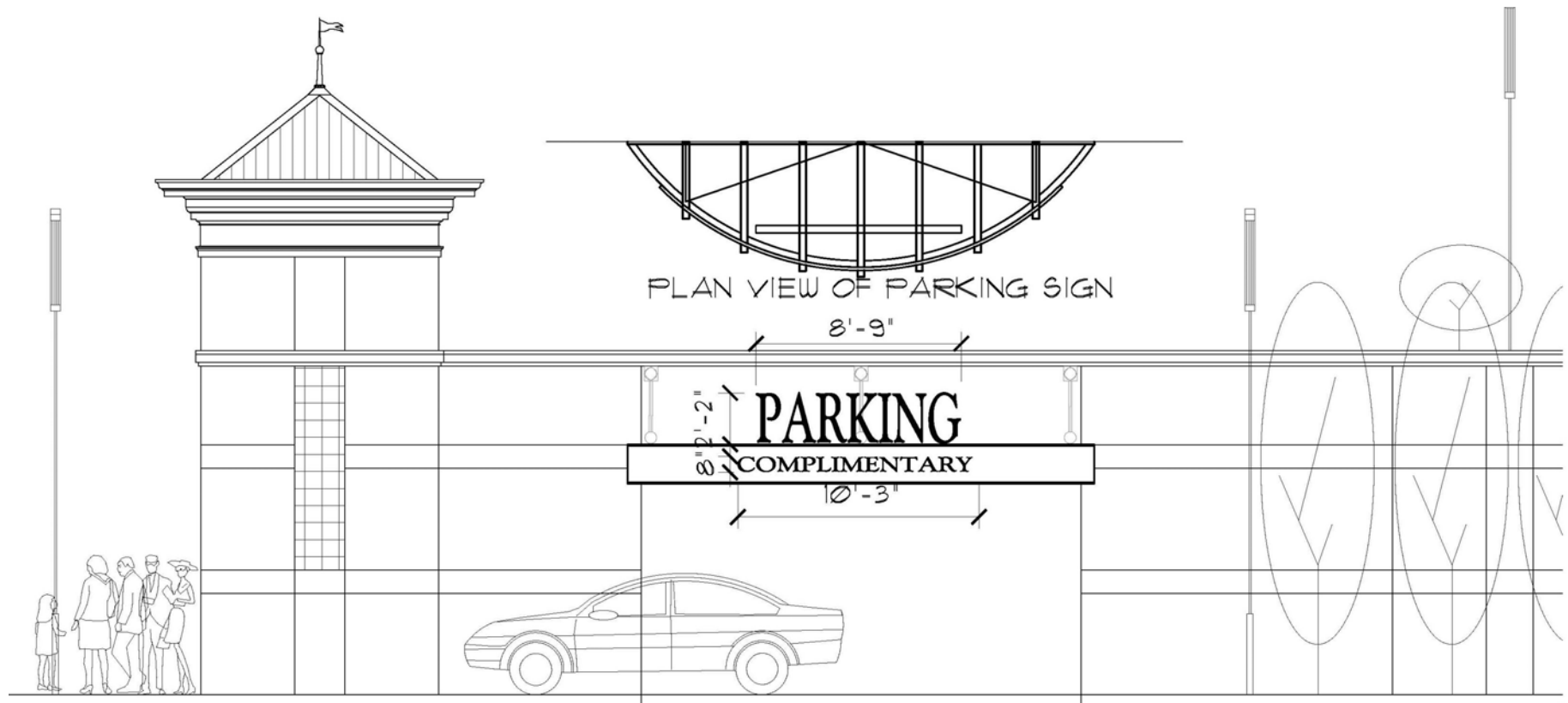

★ **Parking Garage Signs (Vehicular):**

The parking garage serves the office portion of the center. Sign used to provide identification of the parking garage for vehicular traffic. One Parking identification sign will be permitted for each garage entrance. Accessory signs, which inform the visitor of fees, regulations, clearances, and other information, will be permitted not to exceed 15 square feet in area on the outside of the garage. The accessory signs may be either building mounted or free standing, and will complement the architectural style of the garage.

DESCRIPTION:
 Letters Mounted on Metal Canopy
 Maximum Sign area 30 S.F.

GRAPHICS / LETTERING
 Font: Goudy
 Letter Height: 2'2"

■ **Parking Garage Signs (Pedestrian):**

Sign used to provide identification of the parking garage for vehicular traffic.

DESCRIPTION:

- Graphics on 1 side
- 5 S.F. max
- Single color

Wooden or metal blade sign with painted parking sign and shopping center logo (logo optional)

GRAPHICS / LETTERING

Font: Goudy

Letter Height: 1 ft max

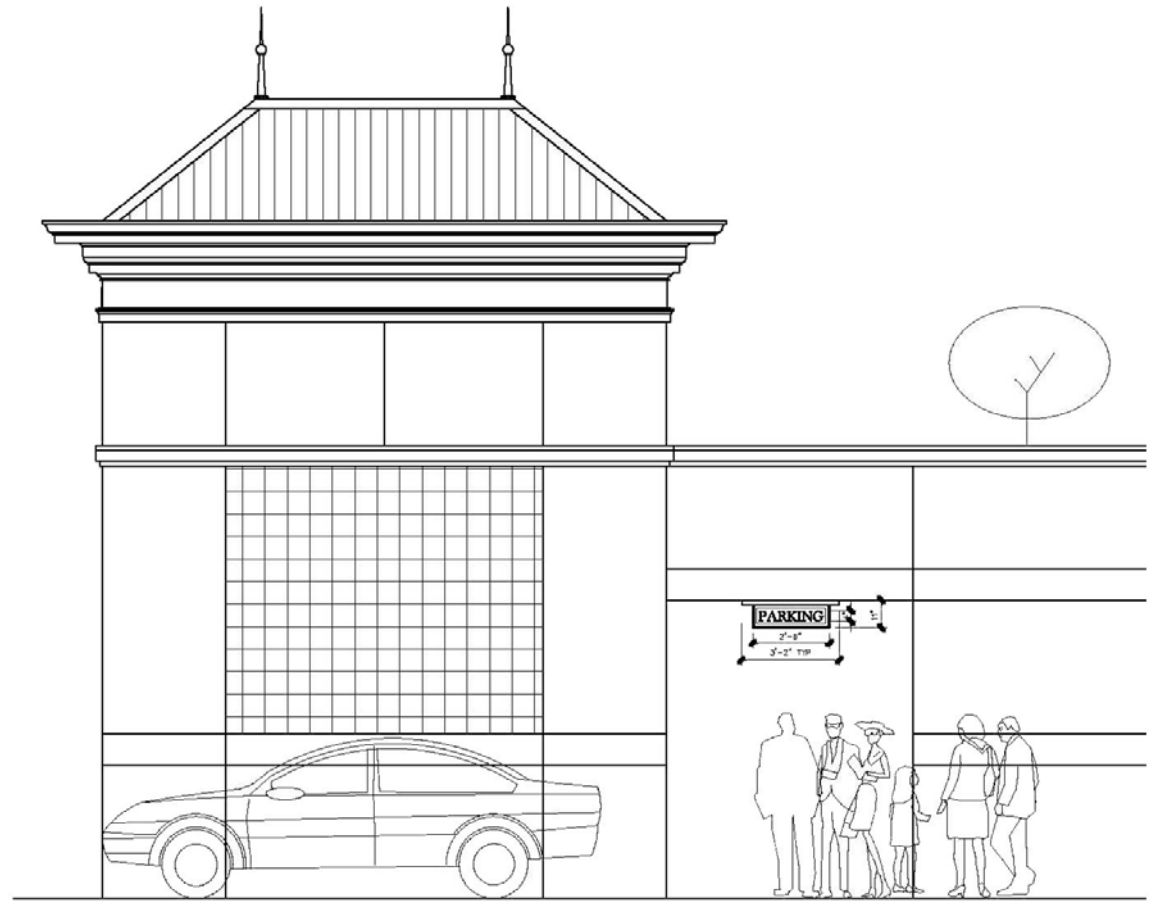

★ Protected Natural Area Sign:

Sign used to preserve the storm water management pond for natural plants and wildlife, and to protect visitors from potential harm.

DESCRIPTION:

Fence Mounted Protected Natural Area Sign

- Signs as needed to protect natural areas
- Maximum size of sign panel 3 s.f.
- Maximum height from ground 4'
- Graphics on 1 side

Mounted on Fence

Wooden or aluminum sign

GRAPHICS / LETTERING

Letter Height: 2.25"

No Illumination

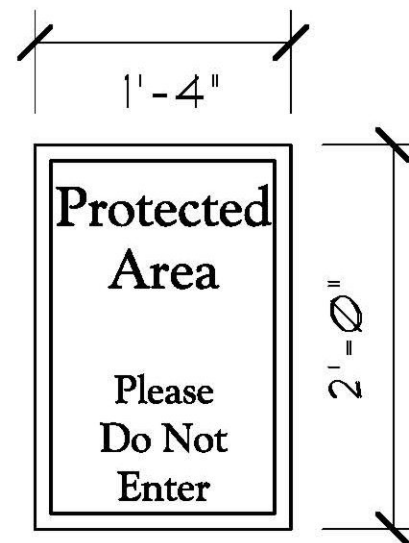

*** Light Pole Banners:**

Light pole banners are used to create a festive and seasonal atmosphere. They may contain the name and logo of the center but will not contain specific Tenant names or logos. They may advertise community or center sponsored events.

DESCRIPTION:

Banners Mounted on Light poles in Parking Areas

18 S.F. per Banner

Banners may be constructed using metal or durable fabrics.

GRAPHICS / LETTERING

Seasonal Graphics Banners and

Shopping Center Identification Banners

7' x 2' 6" Banners

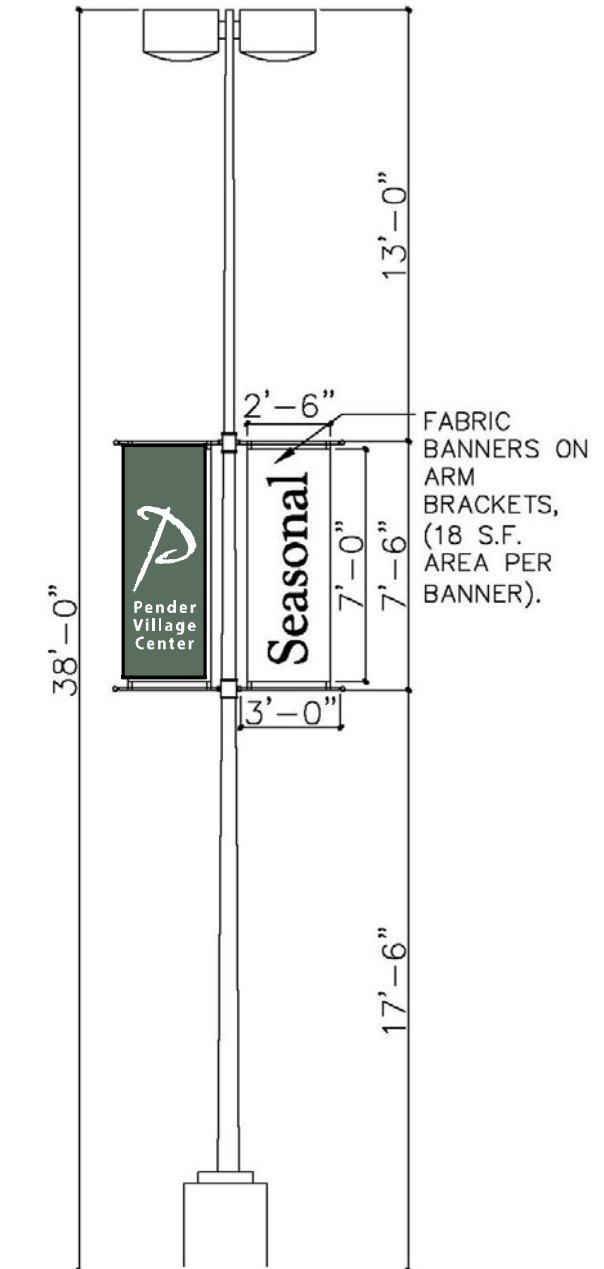

◆ **Historical Marker:**

The historical marker will contain a description of the battle of Chantilly and its historical significance. It will be the standard state historical marker.

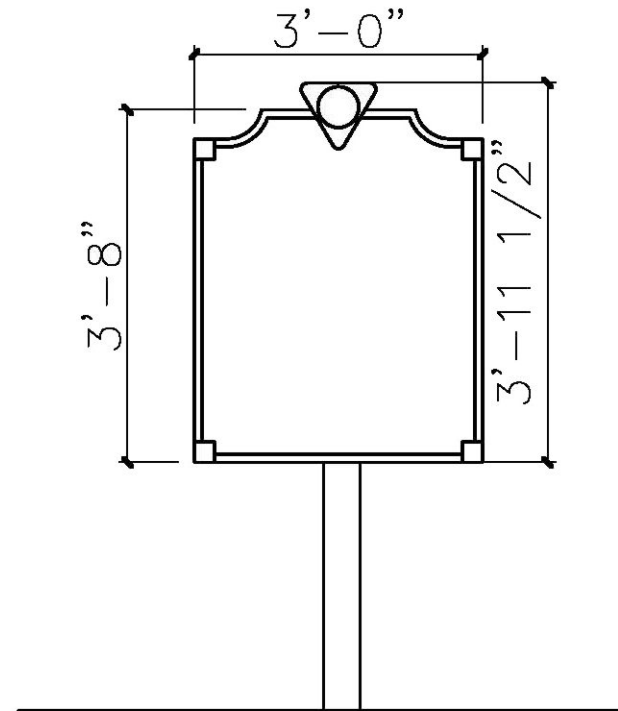

 **Flags:**

DESCRIPTION:

Flags mounted on Flagpoles, located at Pender Mission Center Monument Sign.

GRAPHICS / LETTERING

United States Flag

South Korean Flag

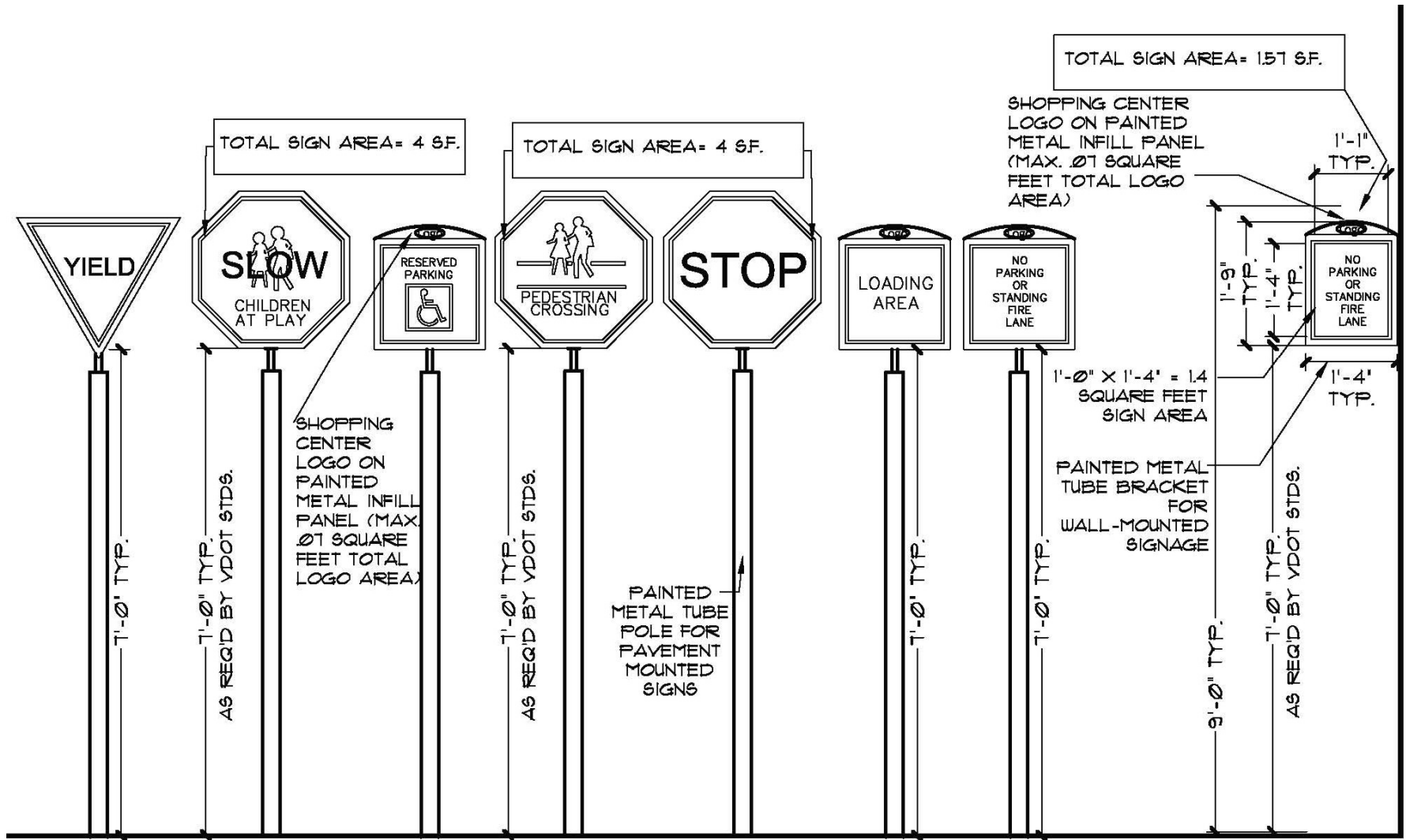

Informational Signs (Stop, Yield, Handicapped, No Parking, Play Area, Loading / Receiving, Pedestrian Crossing)

Traffic Signs used for regulatory purposes will be provided according to all local, state and federal regulations. Sign type, graphics, sizes and heights will conform to these regulations. Signs poles and backs will be painted consistent with the color scheme for the Center.